

DESIGNER LINE DISPLAY REFRIGERATOR

Model: D1RENGD

Natural Refrigerant R-290 Model

Designer Line

1-Section Extra-Wide Reach-In Refrigerator with Hinged Glass Door

D1RENGD - Stainless steel front, aluminum end panels and interior

D1RENSAGD - Stainless steel exterior, aluminum interior

D1RENSSGD - Stainless steel exterior and interior



Options and Accessories

(upcharge and lead times may apply)

Stainless steel case back	Wine rack
Additional epoxy coated steel shelves	Casters
Chrome or stainless steel shelves	Half doors
Rehinging of door (consult factory)	Special electrical req. (consult factory)
Solid door (consult factory)	Shallow depth (consult factory)
Pan slide assemblies	Pass-thru (consult factory)

Consult factory for other model configurations, options and accessories.

Continental[®]
Refrigerator

Toll-Free: 800-523-7138
Phone: 215-244-1400
Fax: 215-244-9579

539 Dunksferry Road
Bensalem, PA 19020
www.continentalrefrigerator.com

Project Name:

Model Specified:

Location:

Item No:

Quantity:

AIA #:

SIS #:

Standard Model Features

REFRIGERATION SYSTEM

Self contained, performance rated "plug" refrigeration system

Natural, environmentally safe, high efficiency R-290 refrigerant¹

Refrigeration system is readily accessible on top of cabinet, separate from the "food zone"

Automatic, hot gas condensate evaporator

Expansion valve system

CABINET ARCHITECTURE

3" non-CFC polyurethane foam insulation

Triple-pane, tempered hinged glass door

Chrome-plated handle

Cam action, lift-off hinges

Self-closing door

Magnetic snap in door gasket

Cylinder lock in door

Heavy duty, epoxy coated steel shelves

Heavy-duty pilaster strips

Adjustable 6" stainless steel legs

MODEL FEATURES

LED interior lighting

Top and side air distribution ducts

Off-cycle defrost

Cabinet upper side panels and refrigeration "plug" system can be removed and reinstalled at job site

Electronic controller with digital display & hi-low alarm

¹ R-290 refrigerant meets all federal and state regulatory requirements.

APPROVAL:

Model Specifications

DIMENSIONAL DATA

Net Capacity (cubic feet)	22 (623 cu l)
Width, Overall (inches)	28 1/2 (724 mm)
Depth, Overall (inches) (including handle)	35 3/8 (899 mm)
Depth (inches) (less door)	32 (813 mm)
Depth (inches) (door open 90°)	58 (1473 mm)
Clear Door Width (inches)	21 7/8 (556 mm)
Clear Door Height (inches)	58 5/8 (1489 mm)
Height, Overall (inches) (including 6" legs)	83 1/4 (2115 mm)
Number of Doors	1
Number of Shelves	4
Shelf Area (square feet)	20.4 (1.9 sq m)
Tray Slide Capacity	24

REFRIGERANT DATA

Condensing Unit Size (H.P.)	1/4
Capacity (BTU per hour)*	1940

ELECTRICAL DATA

Voltage (International)	115/60/1 (220/50/1)
Feed Wires (including ground)	3
Total Amps (International)	5.5 (3.8)
10 ft. Cord/Plug [attached] (International)	Yes (No)

SHIPPING DATA

Height - Crated (inches)	85 1/2 (2172 mm)
Width - Crated (inches)	31 5/8 (803 mm)
Depth - Crated (inches)	42 (1067 mm)
Volume - Crated (cubic feet)	65 (1841 cu l)
Weight Std - Crated (pounds)	345 (156 kg)
Weight SS - Crated (pounds)	365 (166 kg)

* Rating @ +25°F evaporator, 90°F ambient

Figures in parentheses reflect metric equivalents rounded to the nearest whole unit.



Equipped with one NEMA-5-15P Plug
(varies by country)

Model Plan Views

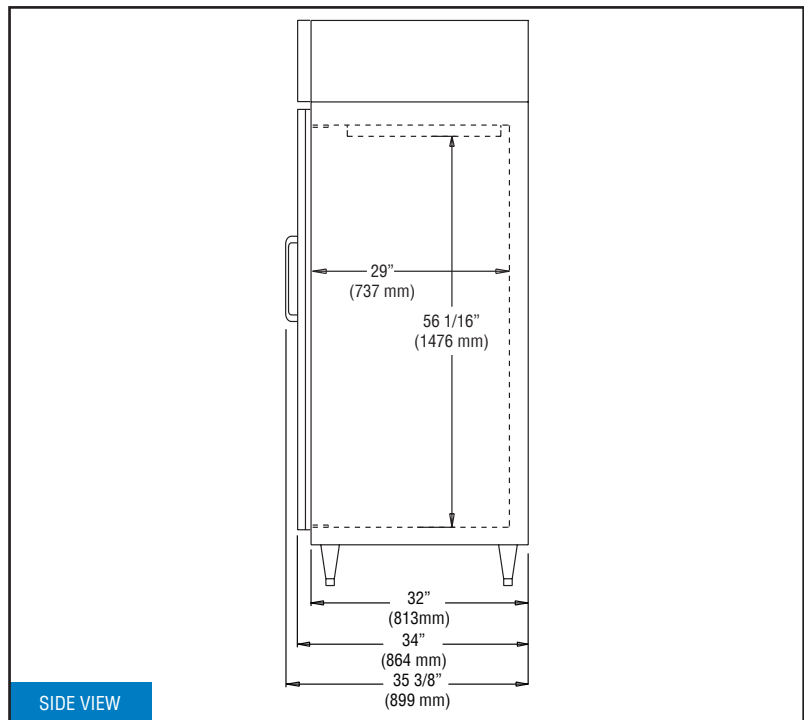
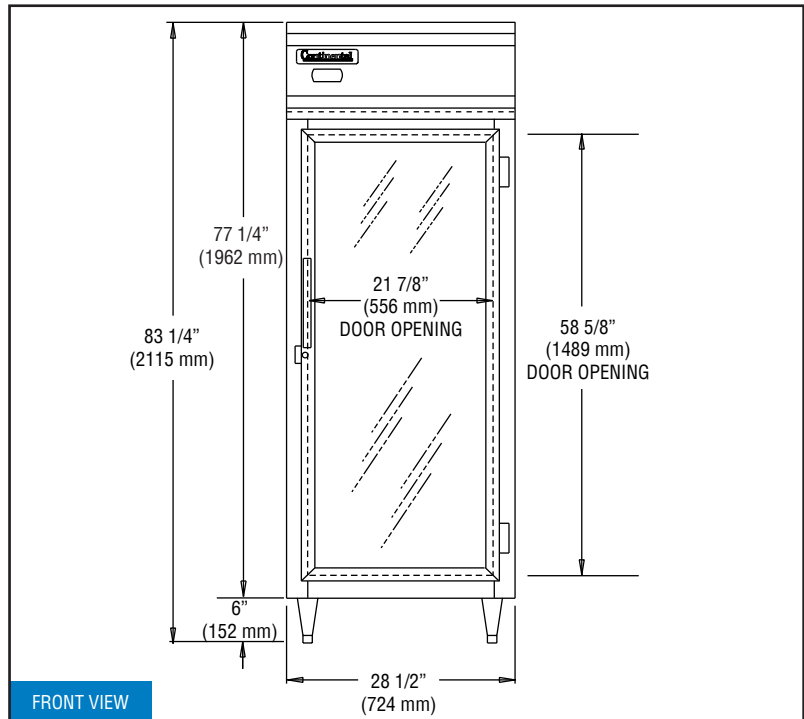

IMPORTANT NOTE: If the cabinet is located directly against a wall and/or under a low ceiling, a minimum clearance of 12" is required on top and 3" on sides and rear.

Continental
Refrigerator

Toll-Free: 800-523-7138
Phone: 215-244-1400
Fax: 215-244-9579

539 Dunksferry Road
Bensalem, PA 19020
www.continentalrefrigerator.com

Due to our continued efforts in developing innovative products, specifications subject to change without notice.

